

# Top Technology

**VIESSMANN**

## *Cooling with Viessmann heat pumps*



- "Natural cooling" – Lower CO<sub>2</sub> emissions than with conventional cooling systems
- Utilisation of all available low ground and groundwater temperatures in summer
- Optimum use in conjunction with heat distribution systems
- Improved regeneration of ground probes and additional storage of energy during summer months
- Cooling COP between 15 and 20, therefore 3 to 4 times greater than conventional air-conditioning systems

# Reversible operation

## Introduction

Conventionally, in Germany, most heat pump systems are used to heat a building and to provide domestic hot water (DHW). Where appropriate, a second device is then installed to cool the building. The option of achieving both functions – heating and cooling – alternately with only one piece of equipment, is still relatively unknown in Germany. However, in the USA, heat pumps which are able to operate as heating and cooling equipment have been firmly established in the market, and consequently enjoy widespread appeal.

A conventional refrigerator and a compressor-driven heat pump work according to the same principle – they differ only in the direction of their heat flow. The most important components (evaporator, condenser, compressor, and expansion valve) are, therefore, identical for both types of equipment. Their principle difference lies in the optimisation of their respective tasks, which in one case aims to increase and in the other to decrease temperatures.

To enable a compressor-driven heat pump to be used for cooling purposes, it would be sufficient to reverse the flow direction of the compressor and the expansion valve, thereby reversing the flow of the refrigerant and consequently the generated heat.

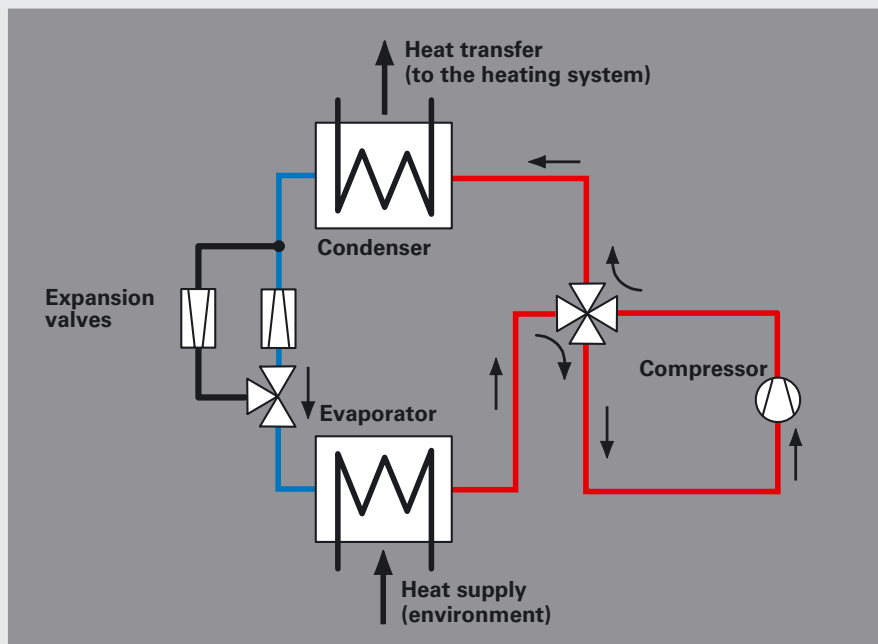

Fig. 1: Simplified function diagram for a heat pump with reversible operation in heating mode

## ***Heat pump with reversible operation in heating mode***

The installation of a four-way valve and a second expansion valve into the refrigeration circuit also have achieved good technical results. This four-way valve enables the flow direction to be changed automatically for the entire system. Through the installation of the four-way valve, the compressor can – whether heating or cooling – always retain its original flow direction.

In heating mode, the compressor pushes the gaseous refrigerant towards the heat exchanger of the heating system. There, the refrigerant condenses and transfers its energy (heat) to the heating system (heating DHW or air) (Fig. 1).

# Reversible operation

## Heat pumps with reversible operation in cooling mode

For cooling, the flow direction is reversed via the four-way valve. The original condenser is now the evaporator, which transfers the heat from the heating system – which in turn has removed heat from the living space – to the refrigerant. Again, the gaseous refrigerant reaches the compressor via the four-way valve, and is transferred from the compressor to the heat exchanger, which transfers the heat to the ambience (Fig. 2).

## Vitotres 343 – Compact System Tower for energy-efficient houses

The compact Vitotres 343 (Fig. 4), which was designed for energy-efficient houses, for example, is an air/water heat pump combined with a mechanical domestic ventilation system. In heating mode (rated output 1.5 kW), the heat pump utilises that proportion of the latent heat in the extracted air, which cannot be utilised by the heat recovery of the ventilation part, to boost the fresh air supply or for DHW heating.

On hot summer days, the heat exchanger in Vitotres 343 used for domestic ventilation, which is designed to recover latent heat, will initially be linked out by a bypass circuit. This results, for example, in night air, which is comparatively cooler than the air inside the building, being directly channelled into the living space. If users want cooler air still, inside the accommodation, the exhaust air/water heat pump automatically switches over to reversible operation. Heat is then actively extracted from the fresh air supply inside the heat pump evaporator, and the cooled air is used to cool the living space. In this mode, the cooling equipment achieves a maximum cooling rating of 1 kW. Warm air from the accommodation is withdrawn via the extracted air. The heating capacity of compressor-driven heat pumps in reversible

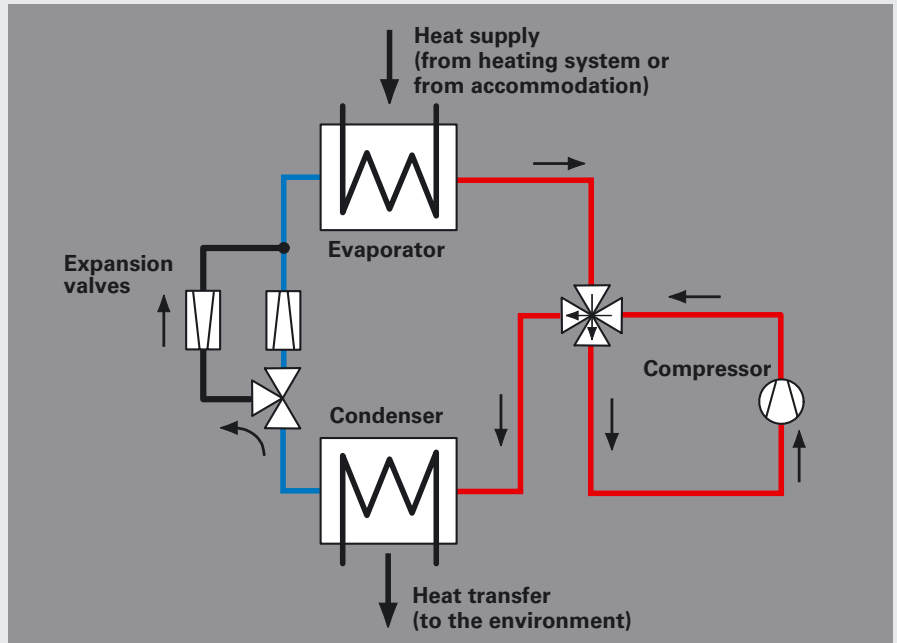

Fig. 2: Simplified function diagram for a heat pump with reversible operation in cooling mode



Fig. 3: Menu-guided control unit CD 70

mode is always a little higher than their cooling capacity. In heating mode, the power consumption required to drive the compressor is converted to heat and is utilised for heating purposes. This heat is also created in cooling mode, since the compressor is needed in this operating mode. However, this inevitably created heat reduces the net result of the theoretically available cooling capacity. The achievable COPs in cooling mode are not as favourable for reversible heat pumps as in heating mode.



Fig. 4: Vitotres 343 – Compact unit for energy-efficient houses: heat pump combined with mechanical domestic ventilation and DHW cylinder

# “Natural Cooling”

Generally during the summer, temperatures inside buildings are higher than underground or in groundwater. Under these conditions, the lower temperatures of the ground/groundwater, which in winter serves as energy source, can be utilised to directly cool the inside of buildings.

For this purpose, some heat pump control units feature a so-called “Natural cooling” function. This function is not possible for air/water heat pumps, due to high outside temperatures in summer.

The “Natural cooling” function can be realised with only a few additional components (heat exchanger, three-way valve and circulation pump). This results in a pleasant additional use for Vitocal heat pumps.

Generally, the capability of this cooling function cannot be compared with air-conditioning equipment or water chillers. The cooling capacity depends on the heat source temperature, the size of the heat source and the period of loading, which may be subject to seasonal fluctuations. For example, experience shows that the ground stores more energy at the end of summer, consequently reducing the cooling capacity.

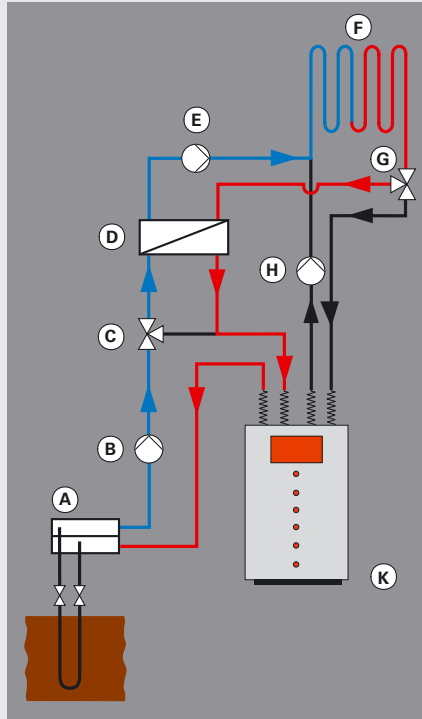

- (A) E.g. ground probe
- (B) Primary pump
- (C) Three-way diverter valve heating/cooling (primary circ)
- (D) Heat exchanger – cooling
- (E) Circulation pump – cooling
- (F) Underfloor heating system
- (G) Three-way diverter valve heating/cooling (secondary circuit)
- (H) Secondary pump
- (K) Vitocal 300 or Vitocal 350 heat pump

Fig. 5: Simplified system diagram for cooling with an underfloor heating system

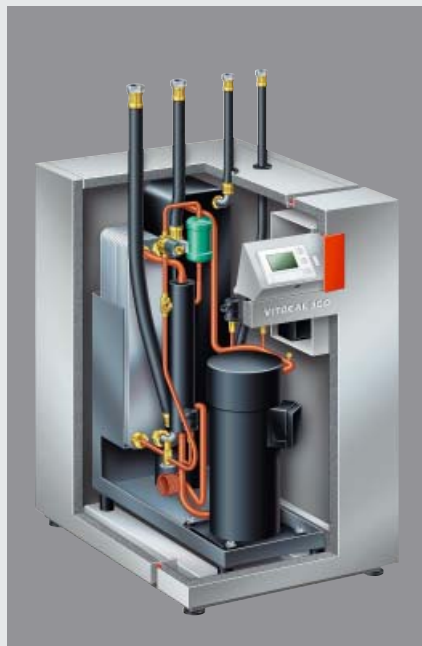

Fig. 6: Vitocal 300 brine/water and water/water heat pump



Fig. 7: Heating circuit control unit CD 60 with soft start and integral cooling and solar function – up to three loading groups can be regulated

# “Natural cooling”

## “Natural cooling” function

In the “Natural cooling” function, the control unit merely starts the primary pump, whilst the compressor remains off. The cool process medium (approx. 5 to 12°C) is therefore transported to the heat exchanger. Subject to system design, the cooling circuit pumps which were started at the same time transport room-tempered heating water to the heat exchanger. Heat is transferred inside the heat exchanger, and cooled heating water can extract heat from the living space via the heat transfer surfaces.

The following systems can be connected to provide direct cooling of the living space:

- Fan convectors
- Chilled ceilings
- Underfloor heating systems
- Building component activation (concrete core heating).



Fig. 8: Air-conditioning ceilings (Fig.: EMCO)



Fig. 9: Fan convectors (Fig.: EMCO)

## Benefits of “Natural cooling”

- Cooling COP between 15 and 20, i.e. 3 to 4 times higher than conventional air-conditioning systems
- Lower CO<sub>2</sub> emissions than conventional air-conditioning systems
- Environmentally responsible
- Optional utilisation of extracted heat for improved regeneration of the heat source and additional energy storage

## “Natural cooling”

“Natural cooling” is a particularly energy-efficient method of cooling buildings, since only modest power is required to drive the circulation pumps, in order to exploit the “cooling source”, i.e. from underground or from groundwater.

During the cooling operation, the heat pump will only be started to provide DHW. The heat pump control unit regulates all essential circulation pumps and diverting valves, captures all necessary temperatures and monitors the dew point.



Fig. 10: Installing an underfloor heating/cooling system



Fig. 11: Using a building component/concrete core – creating an intermediate layer with pipe system

# “Natural cooling”

## Practical tips

For the installation of the “Natural cooling” function in direct connection with heat pumps, we recommend the use of a cooling heat exchanger and a mixer. Reason: Filling the cooling distribution system with anti-freeze reduces the capacity of the heat pump in heating mode, thereby reducing the COP.

A mixer further guarantees the function of a curve, avoiding cycling by the dew point switch. The cooling capacity of the overall system increases, as it works without interruption.

Pipework, fittings and the cooling heat exchanger must be thermally insulated with vapour-proof material.

## Cooling the living space

With conventional air-conditioning systems, cooled air is supplied into the living space via one or more ducts, which also remove heated air. Compact units for energy-efficient houses operate according to the same principle. Both are air-handling units, which provide essential heat transfer through air movement.

Reversible heat pumps and those with “Natural cooling” function, on the other hand, are generally connected to a hot water heating system. On cold days, that system transfers heat from the heating water to the rooms to be heated using heat transfer surfaces.

Radiators are particularly unsuitable for a heat transfer in the opposite direction – i.e. for cooling a room. The comparatively small temperature differential between the heating water and the room temperature in summer, and the relatively small surface area of radiators mean that only a modest heat transfer occurs through convection and radiation. The arrangement of the heat transfer surfaces near floor level is also of little benefit for cooling operations. In addition, radiators are particularly prone to dew corrosion due to their location and design.

Underfloor heating systems are better suited to this purpose because of their larger area. However, cooled air collects at floor level and cannot rise. For this reason, heat from underfloor heating systems is transferred almost exclusively by radiation. On the other hand, the entire floor area is available as a cooling surface, enabling the room temperature to be influenced in accordance with personal requirements.

Improved permeation of the living space with cooled air is achieved by the additional installation of a domestic ventilation system with heat recovery (e.g. Vitovent 300, Fig. 12).

Heat can be dissipated even more effectively via chilled ceilings. Hot air collects under the ceiling and is cooled by its surface. This makes it sink to the floor, enabling hot air to replace it. The resulting circulation leads greater volumes of air past the cooling surface, compared to underfloor cooling. However, chilled ceilings will not generally replace heating systems. For that reason, they are installed in most cases alongside radiators or underfloor heating systems into which they are integrated via an additional heat exchanger, which provides hydraulic system separation.

Fan convectors are especially effective, since these operate with a fan which also creates a controllable volume flow. This allows larger air volumes to be channelled past the heat exchanger surfaces, resulting in the ability to effectively cool a space in a short time. The additional option of being able to vary the volume flow via the fan allows for sensitive space cooling. Also, fan convectors are not prone to dew corrosion, provided any condensate is drained off.

Independent of the method of cooling – reversible operation or “Natural cooling” – the dew point must be monitored by the heat pump control unit in all cases. For example, the surface temperature of an underfloor heating system in cooling mode must not fall below 20°C. The dew point monitor keeps the flow temperature inside the heating system high enough for cooling to prevent the actual temperature falling below the dew point. This prevents the risk of air-borne humidity precipitating on the floor.

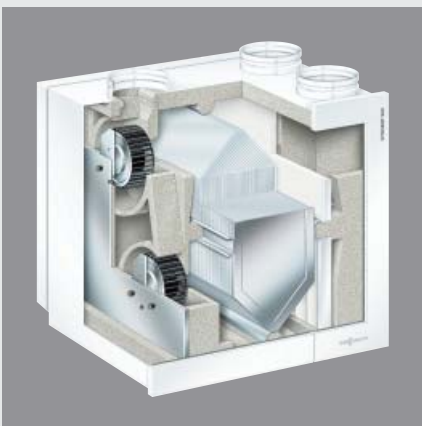

Fig. 12: Vitovent 300 domestic ventilation system with heat recovery

# Cooling with fan convectors

If, fan convectors (on-site provision, e.g. as supplied by EMCO or GEA) are used for cooling operation in summer, alongside the existing heating system, such convectors are hydraulically integrated directly via the brine circuit. The fan convector must therefore be resistant to anti-freeze. A mixer for the cooling circuit is not essential. However, a separate room controller for the fan convector has proven to be advantageous.

A frost stat (on-site provision) must be installed where brine circuit temperatures below freezing cannot be prevented, to block the cooling operation when necessary.

The fan convectors should be sized subject to the flow/return temperature combination 12/16°C (approx.).

As ambient air is circulated by fan convectors, rooms will cool down again relatively rapidly (capacity subject to heat source). The entire room is flushed. Since the air transport is created by a fan, its noise development, too, must be taken into account. Parallel operation (heating and cooling) is feasible with this version. Cooling would then be provided by the fan convector, and heating via the heat pump.

Additional installation costs are incurred in conjunction with conventional heat distribution systems (heating circuit or underfloor heating system).

## Suitable heat pumps:

Vitocal 300, 350 and 343 (not air/water heat pumps).

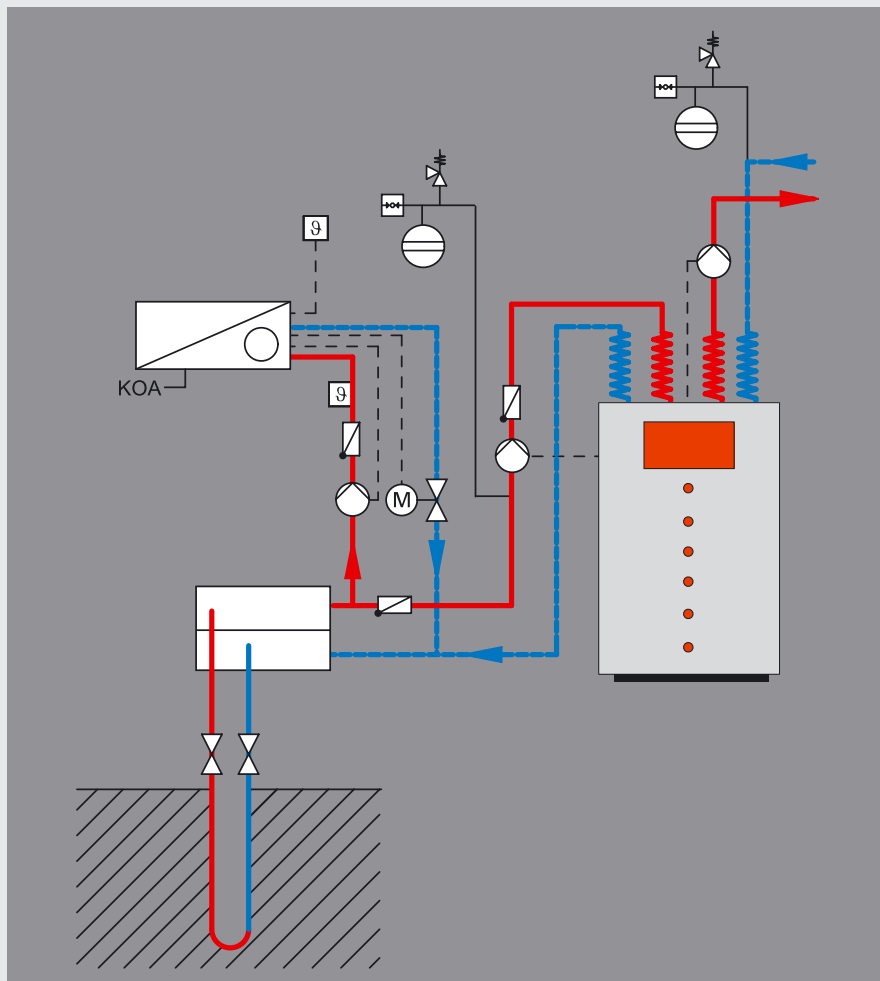

Fig. 13: Cooling with fan convectors

## Practical tips

The fan convector must be equipped with a drain to remove any condensate created during the cooling operation.

Cooling systems with air circulation operate very quickly, making them also suitable for short-term cooling demands.

# Cooling with chilled ceilings

If a chilled ceiling is installed for cooling operation in summer (on-site provision) in addition to an existing heating system (underfloor heating system, radiators), such ceilings are hydraulically integrated into the brine circuit via the cooling heat exchanger. A mixer is required to match the cooling demand of the individual areas to the outside temperature. Similar to a heating curve, the cooling capacity can be accurately matched to the cooling demand via the mixer, which is regulated by the heat pump control unit, using a cooling curve.

To maintain comfort criteria in accordance with DIN 1946, and for preventing dew formation, limits must be maintained with regards to surface temperatures. For instance, the surface temperature of the chilled ceiling must not drop below 17°C. To prevent condensation forming on the chilled ceiling surface, the ceiling flow is equipped with a humidity sensor "Natural cooling" (to capture the dew point). This safely prevents the formation of condensate, even if weather conditions change quite rapidly (e.g. during a thunderstorm).

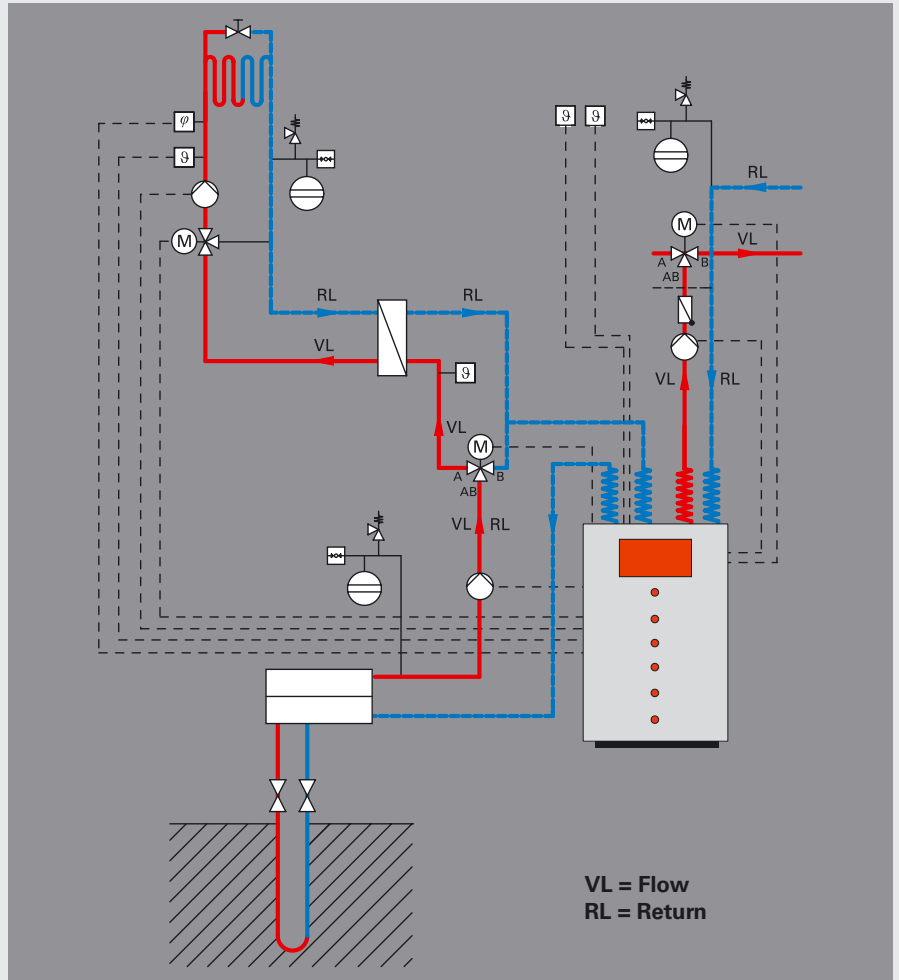

Fig. 14: Cooling with chilled ceilings

## Suitable heat pumps:

Vitocal 300, 350 and 343  
(not air/water heat pumps).

## Practical tips

The chilled ceiling should be sized in accordance with the flow/return temperature pair 14/18°C (approx.). A room temperature sensor is required in the living space to achieve optimum cooling.

Chilled ceilings operate quietly and effectively, as they absorb and convert heat at ceiling level where natural convection takes it. Chilled ceilings incur additional installation costs.

Position humidity sensors so that they can be surrounded by the ambient air in the reference room.

# Cooling with underfloor heating systems

Underfloor heating systems can be used to heat buildings and living spaces as well as to cool them down.

Underfloor heating systems are integrated into the brine circuit via a cooling heat exchanger. A mixer is required to match the cooling demand of the accommodation to the outside temperature. Similar to a heating curve, the cooling capacity can be accurately matched to the cooling demand via the mixer, which is regulated by the heat pump control unit, using a cooling curve.

To maintain comfort criteria in accordance with DIN 1946, and for preventing dew formation, limits must be maintained with regards to surface temperatures. For instance, the surface temperature of the underfloor heating system must not drop below 20°C. To prevent condensation forming on the underfloor heating system surface, the underfloor system flow is equipped with a humidity sensor "Natural cooling" (to capture the dew point). This safely prevents the formation of condensate, even if weather conditions change quite rapidly (e.g. during a thunderstorm).

## Suitable heat pumps:

Vitocal 300, 350 and 343 (not air/water heat pumps).

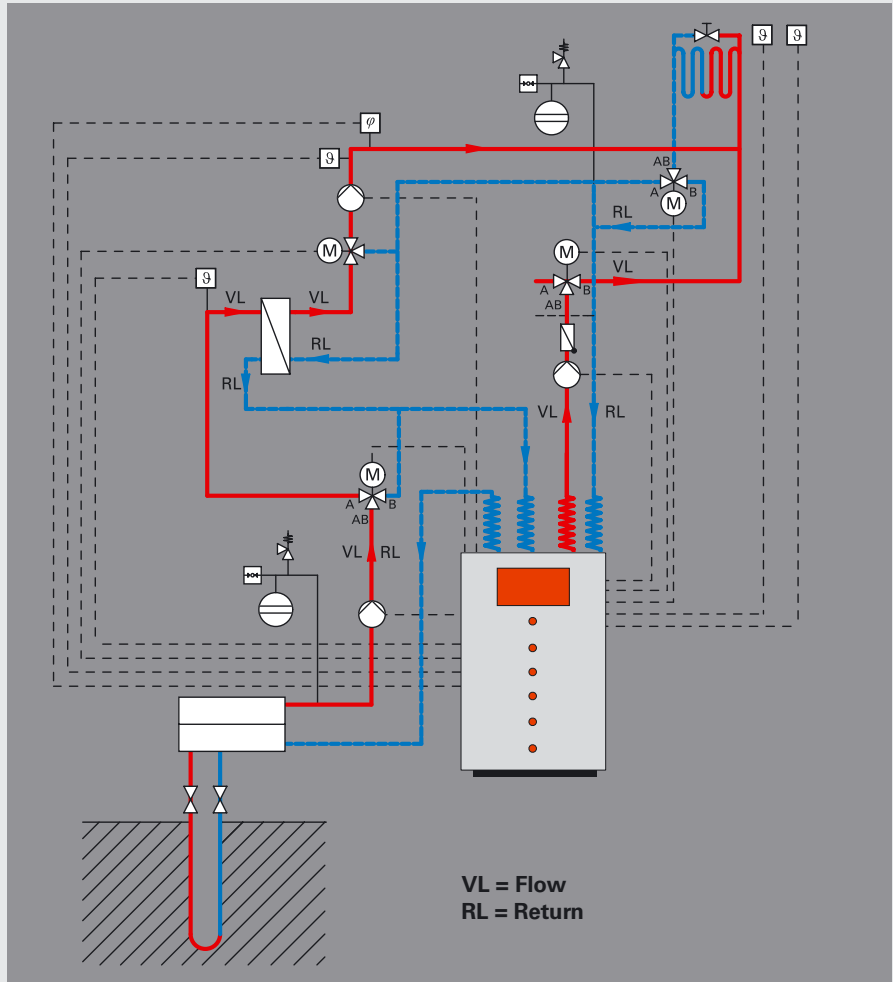

Fig. 15: Cooling with underfloor heating systems

## Practical tips

The underfloor heating systems should be sized in accordance with the flow/return temperature pair 14/18°C (approx.).

The following table can assist in estimating the possible cooling capacity of an underfloor heating system.

Subject to the construction of the underfloor heating system, a room temperature reduction of between 2 and 4 K can be achieved.

The cooling capacity is subject to the effective area, the type of covering and the method of laying.

Floor covering		Tiles			Carpet		
		75	150	300	75	150	300
Distance between pipes	mm						
Cooling capacity with pipe diameter:							
- 10 mm	W/m <sup>2</sup>	45	35	23	31	26	19
- 17 mm	W/m <sup>2</sup>	46	37	25	32	27	20
- 25 mm	W/m <sup>2</sup>	48	40	28	33	29	22

Table 1: Estimated cooling capacity of an underfloor heating system, subject to the distance between pipes (pipework) and floor covering

(assumed flow temperature: approx. 14°C, return temperature: approx. 18°C)

Source: Velta

# Cooling with concrete core activation

With concrete core activation, solid monolithic components of the building to be cooled are moderately cooled. For this, pipes for water circulation are integrated into the relevant building sections. In most cases, ceilings, separating walls or column structures are utilised. During cooling, the anti-freeze solution from the ground probe directly flows through these structural parts. This cools down these sections, which have a high mass and therefore a substantial thermal capacity. This way they can absorb ambient heat from living areas, which is yielded to the ground via the hydraulic system. The structural sections are generally cooled down during the night.

The large effective areas of these systems and their all-round action in the living space result in high levels of comfort.

## Suitable heat pumps:

Vitocal 300, 350 and 343  
(not air/water heat pumps).

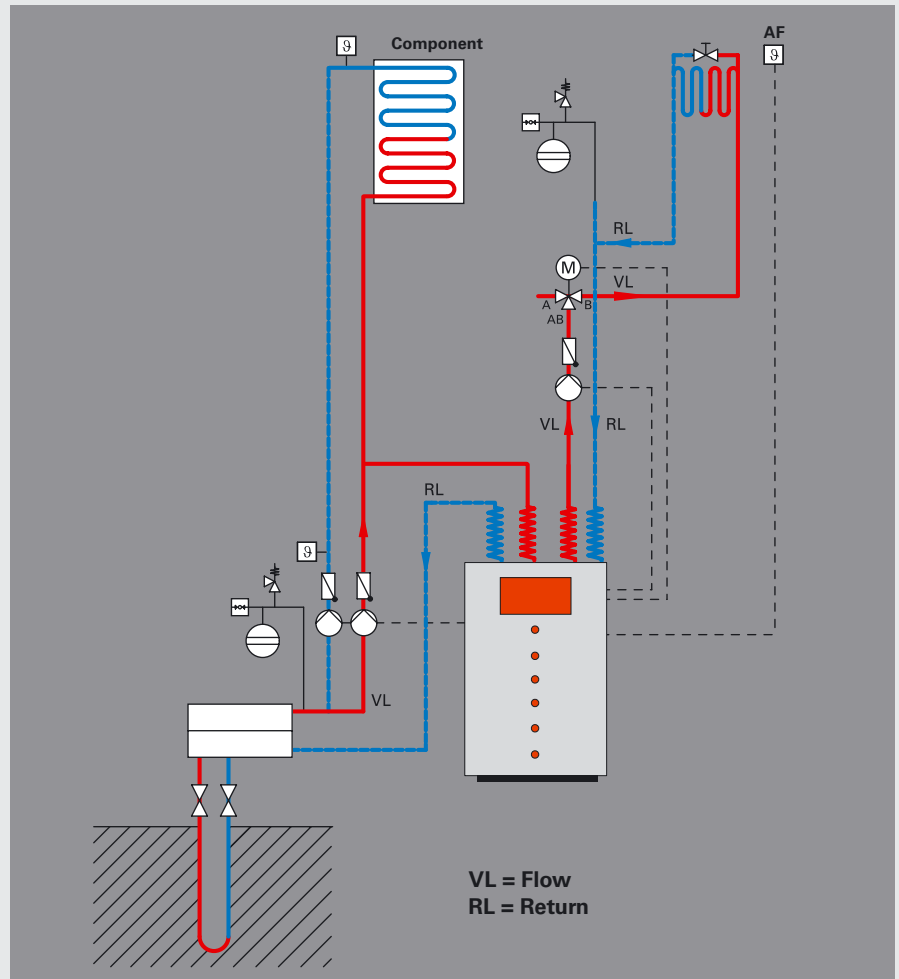

Fig. 16: Cooling with concrete core activation

## Practical tips

The activation of structural sections is unsuitable for achieving short-term rapid cooling results.

Generally, the activation of structural sections is utilised in large buildings and requires a separate control system.



## The Viessmann Group

The Viessmann Group employs approximately 6800 staff worldwide and is one of the foremost manufacturers of heating equipment. For freestanding boilers, Viessmann is the most successful brand in Europe. The Viessmann brand stands for competence and innovation. The Viessmann Group offers a comprehensive range of top-quality, high-tech products along with perfectly matched modular components. For all their diversity, our products have one thing in common: a consistently high standard of quality that is reflected in operational reliability, energy savings, environmental compatibility and user-friendliness.

Many of our developments point the way forward for the heating sector, both in terms of conventional heating technologies and in the field of renewable forms of energy, such as solar and heat pump technology.

In all our developments we pursue our philosophy of always achieving the greatest possible benefit: for our customers, the environment and our partners, the heating contractors.

**The Viessmann Group:**  
**Viessmann Werke**  
**D-35107 Allendorf (Eder)**  
**Tel: + 49 6452 70 - 0**  
**Fax: + 49 6452 70 - 2780**  
**www.viessmann.com**

**Viessmann UK Office:**  
**Viessmann Limited**  
**Hortonwood 30, Telford**  
**Shropshire, TF1 7YP, GB**  
**Tel: + 44 1952 675000**  
**Fax: + 44 1952 675040**  
**E-Mail: info-uk@viessmann.com**

**Viessmann offers you a diverse range of products, which are uniform in quality and adaptable enough to be able to meet any demand and any requirement**



**Wall-mounted oil and gas fired condensing boilers**

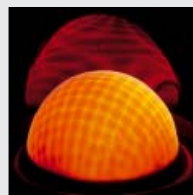

**VIESSMANN**